



WEO PLUG-IN

# CEJN WEO Plug-In

*Hydraulic fitting technology  
– made easy and cost-effective*



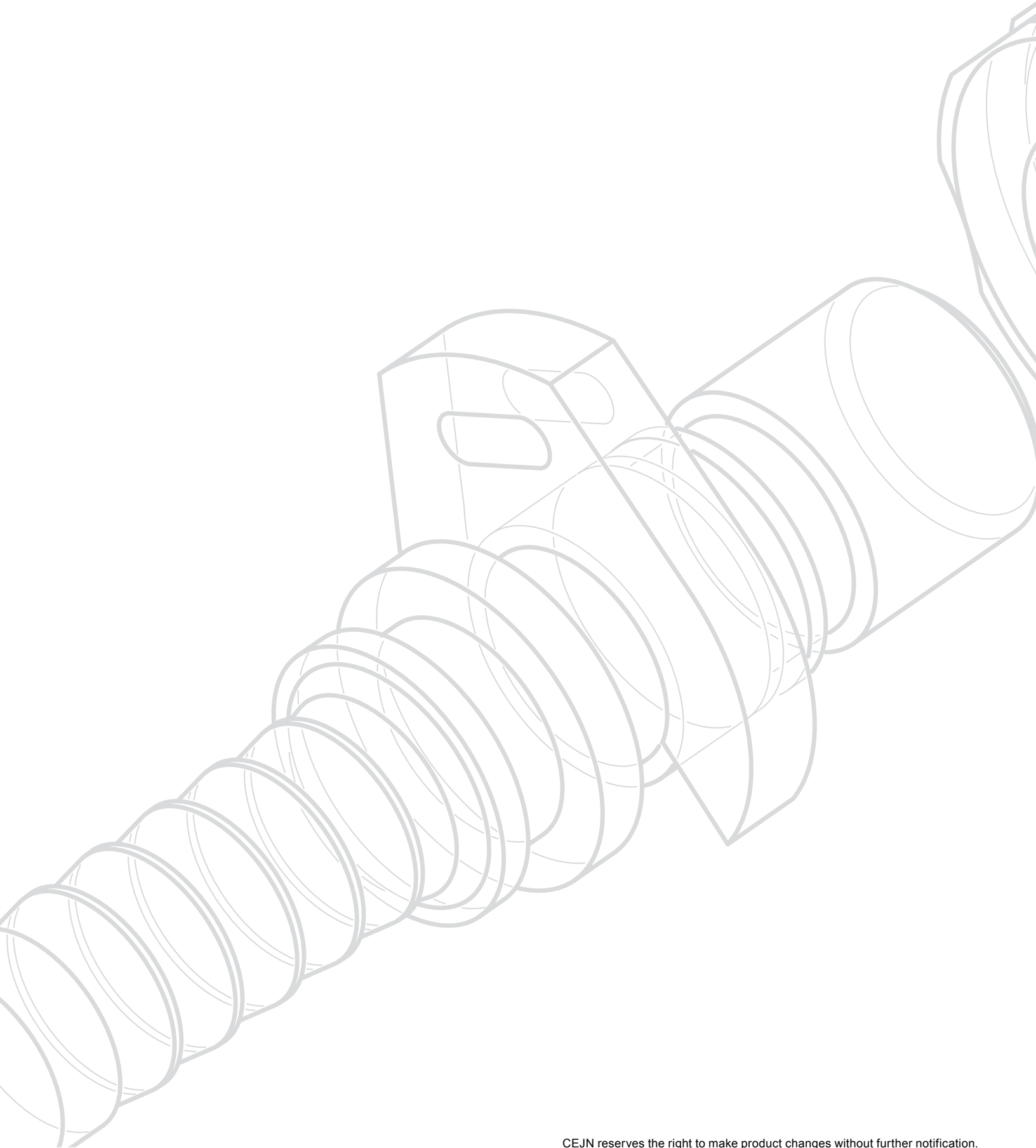

CEJN reserves the right to make product changes without further notification.

# WEO Plug-In Hose Fittings

Save installation time and money by simply  
“plugging in” to hydraulic systems

## Content



**04** CEJN QUICK COUPLING PRODUCTS  
– *Quickly Chosen by Customers Around the World*

---

**06** BENEFITS ADD UP TO ECONOMICAL  
CONNECTIONS

---

**08** CONNECTION/DISCONNECTION

---

**09** TECHNICAL DATA

---

**10** REFERENCES

---

**13** PRODUCT RANGE





# CEJN WEO Plug-In

## – Quickly Chosen by Customers Around the World



**CEJN Corporate Headquarter**  
CEJN AB  
Skövde, Sweden

**CEJN Sales Offices:**  
CEJN Norden AB  
Skövde, Sweden

CEJN Denmark Aps  
Esbjerg, Denmark

CEJN Product GmbH  
Troisdorf, Germany

CEJN France S.A.S  
Paris, France

CEJN AG  
Cham, Switzerland

CEJN Italy S.R.L.  
Milan, Italy

CEJN Ibérica S.L.  
Barcelona, Spain

CEJN Industrial Corporation  
Chicago, USA

CEJN Do Brasil LTDA  
Curitiba, Brazil

CEJN Australia PTY Limited  
Sydney, Australia

CEJN Japan Corporation  
Tokyo, Japan

CEJN Products Far East PTE LTD.  
Singapore City, Singapore

CEJN Products Far East CO, LTD.  
Seoul, Korea

CEJN Shanghai Fluid Systems CO LTD  
Shanghai, China

CEJN Products India Pvt. Ltd.  
Bangalore, India

*When customers all over the world need fluid systems to function without failure, they turn to CEJN for innovative, problem-solving products. CEJN's reputation as a leader in fluid system components began over five decades ago when the company pioneered compressed air couplings at a fledgling assembly plant in Skövde, Sweden.*

Today, that venerable facility stands as the international headquarters for CEJN, which now encompasses sales operations on four continents in 21 countries. The CEJN product line has evolved into a wide range of quick coupling styles that are quickly chosen for applications involving not only the transfer of compressed air, but also hydraulic oils, fluids, gases, and more. Also included in the CEJN product line are accessory products, such as adapters, fittings, hose, hose reels, air-preparation units, and blowguns.

### PRODUCT MODIFICATIONS, ALL-NEW DESIGNS

The company's hard-working commitment to developing new products also includes:

- Modifying existing products when higher performance standards are required – and “off-the-shelf” components won't do. By continually investing in new processes and technologies, CEJN has the capability to modify products that exceed their original performance parameters and customer expectations.
- Designing and manufacturing limited quantities of custom couplings that are needed by customers to replace troublesome products or build into new or existing applications. CEJN provides complete product solutions from design to installation-ready components that are qualified, tested, and backed by after-sale support.

Whether it's a special coupling requirement for material, temperature range, end connection, or flow rate, CEJN engineers analyze each requirement and determine whether to build it into an existing product or an all-new design.

### PIONEERING SPIRIT LEADS TO WEO PLUG-IN HOSE FITTINGS

In fact, this pioneering spirit has led to CEJN's entry into threadless connector market with the development of WEO Plug-In hose fittings – CEJN's response to customer inquiries for end connections that simply “plug in” to hydraulic systems. The innovative click-to-connect feature of WEO fittings eliminates the need for tools or wrenches that are needed to connect and disconnect traditional threaded fittings.

WEO fittings are leak-free and slash downtime for assembly and field maintenance, since only a common screwdriver is needed to remove hose assemblies.

As more and more applications industry-wide are being converted from threaded to threadless connectors, WEO Plug-In hose fittings are becoming the connection of choice by well-known original equipment manufacturers for critical equipment applications.

Backed by extensive laboratory and field-testing, WEO fittings, offered with numerous connection options, are being used by leading companies that supply products all over the world.

### PARTNERING WITH HOSE MANUFACTURERS

In fact, because of the industry's acceptance of CEJN threadless fittings, several international hose manufacturers have partnered with CEJN in offering their customers hose assemblies equipped with CEJN WEO products. These assemblies are of high interest to customers that are looking for a reliable, proven threadless design that is backed by a premier hose manufacturer.

As a result, more and more global customers are “plugging in” to hydraulic systems without tools or wrenches by specifying problem-solving WEO Plug-In hose fittings from CEJN, your quick connect specialist.



ISO 9001 certified since 1995.  
ISO 14001 certified since 2006.



## **Add up the Features with WEO Plug-In Hose Fittings**

- + Downtime, installation time dramatically reduced
- + Easy to connect and disconnect
- + Leak-free connections
- + No follow-up tightening needed
- + Minimum space requirement enables new system designs
- + Work injuries associated with connection/disconnection are eliminated
- + Longer hose life
- + Easy to service

---

**= Lower Overall Cost**

# Benefits Add Up to Economical Connections



## DOWNTIME, INSTALLATION TIME DRAMATICALLY REDUCED

CEJN WEO Plug-In hose fittings slash downtime and installation time for original equipment manufacturers. The click-to-connect and self-aligning features of the fittings make them easy to install in hydraulic systems, which will lead to dramatically cost reduce.

## EASY TO CONNECT AND DISCONNECT

WEO fittings are designed with an innovative click-to-connect feature that provides easy engagement of the product's male and female halves, without the aid of tools or wrenches.

## LEAK-FREE CONNECTIONS

Since WEO fittings "plug in" tightly to hydraulic systems, hydraulic leakage is virtually eliminated.

## NO FOLLOW-UP TIGHTENING NEEDED

WEO fittings automatically lock into place, eliminating the need for tightening during follow-up checks.

## MINIMUM SPACE REQUIREMENT ENABLES NEW SYSTEM DESIGNS

WEO fittings make it easier to build compact, reliable hydraulic systems that include hose and tubes, since access for hand-tool clearance is not a requirement.

## WORK INJURIES ASSOCIATED WITH CONNECTION/DISCONNECTION ARE ELIMINATED

Since WEO fittings are quick and easy to connect and disconnect, physical injuries associated with tightening and untightening traditional threaded connections no longer occur.

## LONGER HOSE LIFE

WEO fittings are self-aligning, which eliminates twisted hose that can occur during connection, and thereby extend hose life.

## EASY TO SERVICE

The simple connection and disconnection of WEO fittings make it easy to replace hose assemblies with only a common screwdriver, even in confined or difficult-to-reach applications.

## LOWER OVERALL COST

The click-to-connect feature of WEO threadless fittings greatly reduces installation time for equipment manufacturers. The fittings' ability to eliminate leakage and improve accessibility also add to their lower overall cost than threaded-type fittings.



# Connection

1. Make sure the assembly stop is in place and the release ring runs freely in its groove.

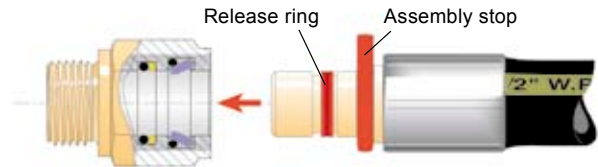
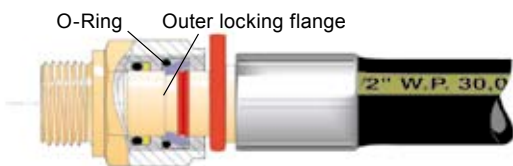
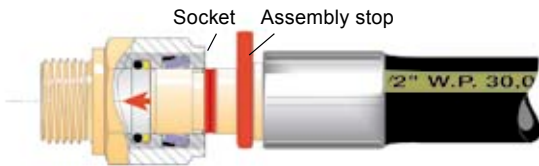
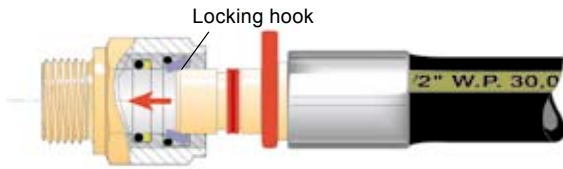

2. Push the plug all the way in until the assembly stop touches the socket.

3. The O-ring presses the locking hooks inwards so that they grip the outer locking flange on the plug. The coupling is now locked and cannot be disconnected.

# Disconnection

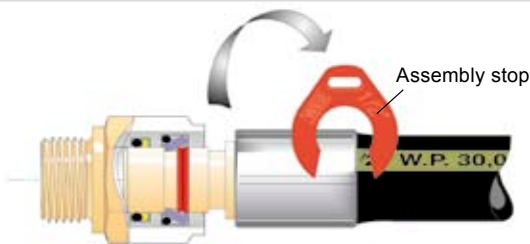

2. Push the plug all the way in so that the release ring pushes the locking hooks aside.

3. Pull the plug out.

1. Using a screwdriver, remove the assembly stop.

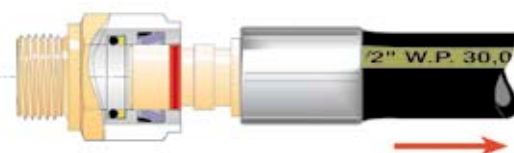
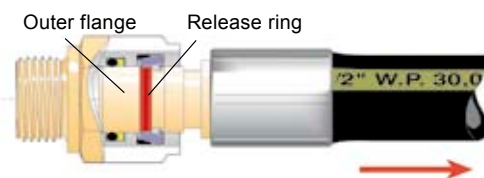
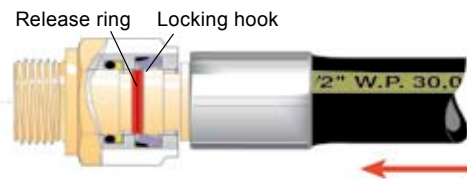

# Technical Data

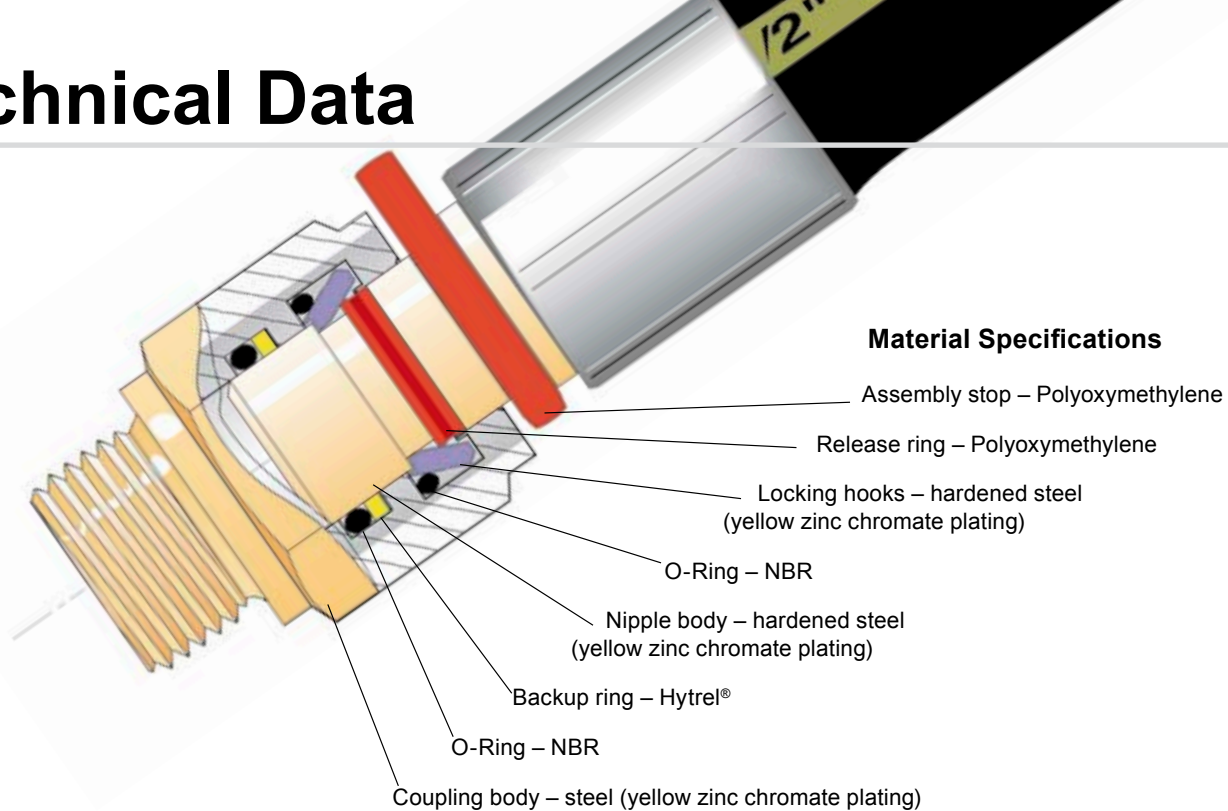

## Tests

WEO Plug-In hose fittings have been tested and approved by the Swedish Institute of Materials Testing and Research to SS-ISO 8032 – Half Omega Test, and have been burst tested to a minimum pressure of four times the working pressure. The fittings have also been tested and approved by TÜV, Germany.

## Temperature Range

-22°F – +212°F (-30°C – +100°C)

## Working Pressure, Safety Factor

WEO fitting sizes 1/4 inch through 3/4 inch have a maximum working pressure of 5075 PSI (350 bar). The 1-inch size has a maximum working pressure of 3625 PSI (250 bar). A minimum safety factor of 4:1 between burst pressure and working pressure applies to all sizes.

Note: Working pressure may vary among sizes. Refer to the data for each product range.

Hose Size Working Pressure			Hose Standards		
			SAE	DIN	EN
-03	3/16"	5076 PSI	100R1A	1ST 20022	853-1ST
-04	1/4"	5076 PSI	100R1AT	1SN 20022	853-1SN
-05	5/16"	5076 PSI	100R2A	2ST 20022	853-2ST
-06	3/8"	5076 PSI	100R2AT	2SN 20022	853-2SN
-08	1/2"	5076 PSI	100R9R	4SP 20023	856-4SP
-10	5/8"	5076 PSI			857-1SC
-12	3/4"	5076 PSI			857-2SC
-16	1"	3626 PSI			

## Compatible Hose Styles

WEO Plug-In hose stems can be crimped onto most common styles of single- and multiple-braid hydraulic hose up through 1 inch (-16 size) and light spiral reinforced hose. Use the standard tooling and corresponding collar (sleeve, ferrule, socket, etc.) for each type of hose. Crimping instructions see Instructions at [www.weoplugin.com](http://www.weoplugin.com).



## WEO Products Are a Natural Fit at Kanglim

“Here at Kanglim, we place a major emphasis on using only state-of-the-art hydraulic technology in our production of truck-mounted cranes and special-purpose vehicles. This kind of commitment to innovation makes WEO Plug-In hose fittings a natural fit at our assembly facility in Chungcheongbuk-do, Korea.

“WEO fittings are used on high-pressure oil lines on the rotating arms of Kanglim auger cranes. The self-alignment of WEO fittings allows the connecting hose to move freely during installation, which has eliminated the problems of twisted hose and resultant shortened hose life.

“The use of threadless WEO fittings also has enabled us to reduce assembly time for the auger cranes, since the fittings require only a quick ‘click’ to connect and disconnect them.

“Because of the important, problem-solving benefits of WEO products, I would not hesitate to recommend them to other companies with similar applications.”

**CONTACT PERSON:**  
Chan Ho Kim  
Deputy General Manager  
Crane Technical Design –  
Research & Development Center

**COMPANY:**  
Kanglim Company, Ltd.  
Chungcheongbuk-do, Korea  
[www.kanglim.com](http://www.kanglim.com)

## Brokk Makes Buildings Come Tumbling Down with Aid of WEO Products



“Getting in and out of job sites on time in order not to disrupt critical time schedules and budgets is very important to us. Therefore, it is crucial that Brokk remote-controlled demolition robots are equipped with components that are quick and easy to repair.

“For this reason, Brokk AB has supplied WEO Plug-In hose fittings on hydraulic oil lines on a robot being used for sorting and demolition in a nuclear waste station.

**CONTACT PERSON:**  
Anders Norberg, Design Manager

**COMPANY:**  
Brokk AB, Skellefteå, Sweden  
www.brokk.com

“The product has appealed to us because it is so quick and easy to install and makes replacing hose assemblies almost effortless.

“At job sites, such as nuclear waste stations in which it can be extremely tough to make hose assembly replacements due to the dangerous working environment, WEO products may be just the solution we need.”

## Rottne Logging Equipment Clears the Way for WEO Fittings

“Rottne logging cranes have very compact designs, which do not offer a lot of clearance area for installing and repairing hose assemblies with traditional threaded fittings and working with the required hand tools.

“CEJN’s WEO Plug-In fittings are a handy product for us because they are quick and easy to connect and disconnect without wrenches.

“Here at our assembly facility in Rottne, Sweden, we use them on hydraulic lines on the cranes’ extension cylinders.

“In the past, we have found that with screw-in fittings, it is impossible to replace these hydraulic lines without completely dismantling the cylinders.

“With WEO fittings, downtime for field maintenance is minimal, since only a screwdriver is needed to remove the assemblies, and replacements just click into place.

“We have been using WEO products for the past five years and have had no problems with their installation or performance.”



**CONTACT PERSON:**  
Göran Johannisson  
Design Engineer

**COMPANY:**  
Rottne Industri AB, Rottne, Sweden  
www.rottn.com

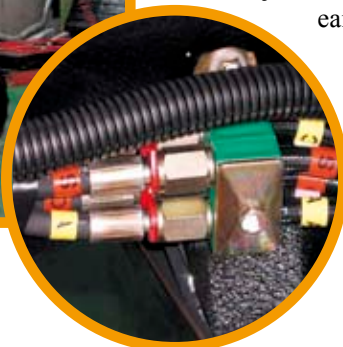

## WEO Products Are Earth Moving at Komatsu

“For the past two years, we have been using WEO connectors to join hose assemblies to servo controls on our Komatsu earth moving equipment. These threadless connectors appealed to us because of the difficulty we experienced in installing threaded connectors in confined areas.

“WEO connectors are easy to install and also provide easy maintenance and reliable sealing. Since we build hundreds of machines each month that require literally thousands of hose assemblies, these are important benefits to us.

“We purchase the WEO-equipped hose assemblies from a hose manufacturer that, along with CEJN, provides valuable technical assistance. WEO’s reliable performance and its support from two companies give us confidence in the product.”

**CONTACT PERSON:**

Gianni Contato, Supplier Auditor – Quality Assurance Department

**COMPANY:**

Komatsu Utility Europe, Este, Italy  
www.komatsu.it

## WEO Products Give Palfinger Cranes a Lift

“The fact that threadless connectors do not require a lot of space for installation is what led us to try them on our loading cranes.

“The hydraulic control valves on Palfinger cranes have numerous hose connections, but are located in an area with virtually no space for hand tools that are required for making threaded connections.

“With our knowledge of threadless connectors, we decided to try CEJN WEO Plug-In hose fittings on the valve banks. After determining what fitting heat treatment processes would and wouldn’t work for us, we are pleased with WEO’s performance.

“Installing hose assemblies is no longer a problem at our assembly facility here in Salzburg, Austria, or on the job site when hose replacements are needed.

“I would highly recommend WEO products to other manufacturers that have limited access space on their equipment. WEO fittings that automatically lock into place have been the answer for us.”



**CONTACT PERSON:**

Reinhard Sunkler, Purchasing – Hydraulic Parts Procurement

**COMPANY:**

Palfinger AG, Salzburg, Austria  
www.palfinger.com

# Product Range



# Nipple

## Straight hose connection

**Series 710:** Nipple for SAE 100R1/R2 hose or equivalent

**Working Pressure**

1/4"	5076 PSI (350 bar)
3/8"	5076 PSI (350 bar)
1/2"	5076 PSI (350 bar)
3/4"	5076 PSI (350 bar)
1"	3625 PSI (250 bar)

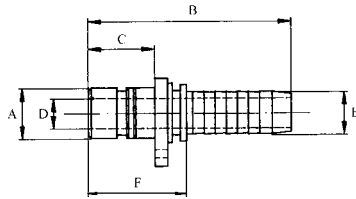

	Part No.	Connection (E)	A	B	C	D	F	
NIPPLE – Straight	Series 710, 1/4"	14 710 0403	3/16" (5.25)	10.0	54.5	19.0	2.8	29.2
		14 710 0404	1/4" (6.9)	10.0	58.0	19.0	4.5	30.0
	Series 710, 3/8"	14 710 0604	1/4" (6.9)	13.0	61.0	22.0	4.5	33.0
		14 710 0605	5/16" (8.6)	13.0	61.0	22.0	5.6	33.0
		14 710 0606	3/8" (10.1)	13.0	63.0	22.0	7.0	33.0
	Series 710, 1/2"	14 710 0806	3/8" (10.1)	16.0	63.0	22.0	7.0	33.0
		14 710 0808	1/2" (13.6)	16.0	64.0	22.0	9.5	33.0
	Series 710, 3/4"	14 710 1208	1/2" (13.6)	23.0	73.5	31.0	9.5	42.5
		14 710 1210	5/8" (16.8)	23.0	77.5	31.0	13.0	43.3
		14 710 1212	3/4" (20)	23.0	82.0	31.0	15.0	43.0
	Series 710, 1"	14 710 1616	1" (26.2)	30.0	100.5	38.5	21.0	54.0

# Nipple

## 45° Hose connection

**Series 712:** Nipple for SAE 100R1/R2 hose or equivalent

**Working Pressure**

1/4"	5076 PSI (350 bar)
3/8"	5076 PSI (350 bar)
1/2"	5076 PSI (350 bar)
3/4"	5076 PSI (350 bar)

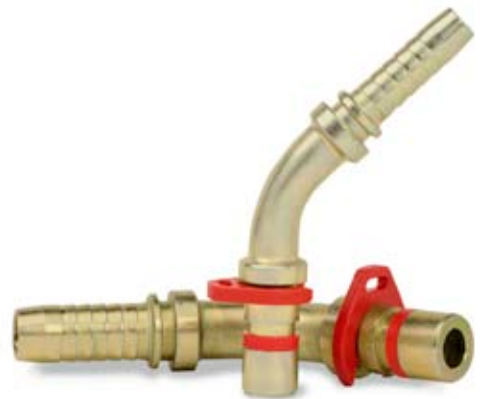
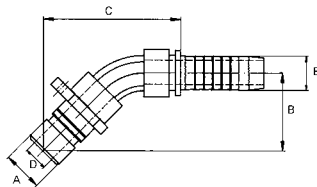

	Part No.	Connection (E)	A	B	C	D	
NIPPLE – 45°	Series 712, 1/4"	14 712 0404	1/4" (6.9)	10.0	28.0	51.0	4.5
	Series 712, 3/8"	14 712 0606	3/8" (10.1)	13.0	33.0	59.0	7.0
	Series 712, 1/2"	14 712 0808	1/2" (13.6)	16.0	36.0	66.0	9.0

# Nipple

## 90° Hose connection

**Series 714:** Nipple for SAE 100R1/R2 hose or equivalent

**Working Pressure**

- 1/4" 5076 PSI (350 bar)
- 3/8" 5076 PSI (350 bar)
- 1/2" 5076 PSI (350 bar)
- 3/4" 5076 PSI (350 bar)

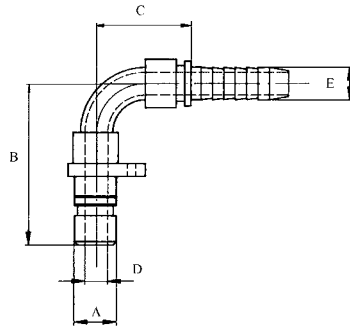

		Part No.	Connection (E)	A	B	C	D
NIPPLE – 90°	Series 714, 1/4"	14 714 0404	1/4"(6.9)	10.0	51.0	34.0	4.5
	Series 714, 3/8"	14 714 0606	3/8"(10.1)	13.0	60.0	39.0	7.0
	Series 714, 1/2"	14 714 0806	3/8"(10.1)	16.0	61.0	39.0	7.0
		14 714 0808	1/2"(13.6)	16.0	69.0	48.0	9.0
	Series 714, 3/4"	14 714 1212	3/4"(20)	23.0	104.5	75.0	14.5

# Nipple

## Stop

**Working Pressure**

- 1/4" 5076 PSI (350 bar)
- 3/8" 5076 PSI (350 bar)
- 1/2" 5076 PSI (350 bar)
- 3/4" 5076 PSI (350 bar)
- 1" 3625 PSI (250 bar)

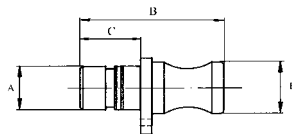

		Part No.	A	B	C	E
NIPPLE – Stop	Series 723, 1/4"	14 723 0400	10.0	43.0	19.0	12.0
	Series 723, 3/8"	14 723 0600	13.0	50.0	22.0	16.0
	Series 723, 1/2"	14 723 0800	16.0	50.0	22.0	19.0
	Series 723, 3/4"	14 723 1200	23.0	59.0	31.0	25.0
	Series 723, 1"	14 723 1600	30.0	75.0	38.5	33.0

# Coupling

## External G-Thread (ISO 228/1)

### Working Pressure

1/4"	5076 PSI (350 bar)
3/8"	5076 PSI (350 bar)
1/2"	5076 PSI (350 bar)
3/4"	5076 PSI (350 bar)
1"	3625 PSI (250 bar)

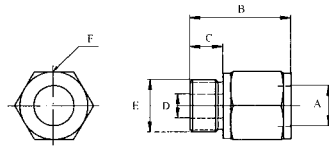

	Part No.	Connection (E)	A	B	C	D	F (hexagon)	
COUPLING – G-Thread	Series 810, 1/4"	14 810 0404	G 1/4"	10.0	38.4	12.0	4.5	20
	Series 810, 3/8"	14 810 0606	G 3/8"	13.0	41.9	12.0	7.0	24
	Series 810, 1/2"	14 810 0808	G 1/2"	16.0	43.5	14.0	9.5	28
	Series 810, 3/4"	14 810 1212	G 3/4"	23.0	56.0	16.0	15.0	36
	Series 810, 1"	14 810 1616	G 1"	30.0	67.0	18.0	21.0	41

# Coupling

## Stop

### Working Pressure

1/4"	5076 PSI (350 bar)
3/8"	5076 PSI (350 bar)
1/2"	5076 PSI (350 bar)
3/4"	5076 PSI (350 bar)
1"	3625 PSI (250 bar)

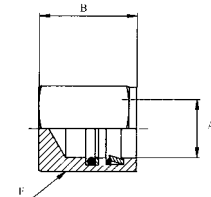

	Part No.	A	B	F (hexagon)	
COUPLING – Stop	Series 811, 1/4"	14 811 0400	10.0	29.4	20
	Series 811, 3/8"	14 811 0600	13.0	31.3	24
	Series 811, 1/2"	14 811 0800	16.0	32.3	28
	Series 811, 3/4"	14 811 1200	23.0	44.0	32
	Series 811, 1"	14 811 1600	30.0	55.0	41

# Coupling

## Straight hose connection

**Series 817:** Coupling for SAE 100R1/R2 hose or equivalent

**Series 818:** Coupling for SAE 100R9R multi-spiral hose

**Working Pressure**

1/4"	5076 PSI (350 bar)
3/8"	5076 PSI (350 bar)
1/2"	5076 PSI (350 bar)
3/4"	5076 PSI (350 bar)
1"	3625 PSI (250 bar)

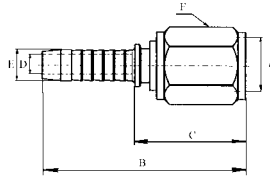

	Part No.	Connection (E)	A	B	C	D	F (hexagon)	
COUPLING— Straight	Series 817, 1/4"	14 817 0404	1/4" (6.9)	10.0	62.4	34.0	4.5	20
	Series 817, 3/8"	14 817 0606	3/8" (10.1)	13.0	66.9	36.0	7.0	24
	Series 817, 1/2"	14 817 0808	1/2" (13.6)	16.0	67.0	36.0	9.5	27
	Series 817, 3/4"	14 817 1212	3/4" (20)	23.0	87.0	48.0	15.0	32
	Series 817, 1"	14 817 1616	1" (26.2)	30.0	105.0	58.5	21.0	41
	Series 818, 3/4"	14 818 1212	3/4" (19.8)	23.0	95.0	49.0	15.0	32
	Series 818, 1"	14 818 1616	1" (26.2)	30.0	115.0	60.0	21.0	41

# Coupling

## SAE J514 O-Ring Boss

**Working Pressure**

1/4"	5076 PSI (350 bar)
3/8"	5076 PSI (350 bar)
1/2"	5076 PSI (350 bar)
3/4"	5076 PSI (350 bar)
1"	3625 PSI (250 bar)

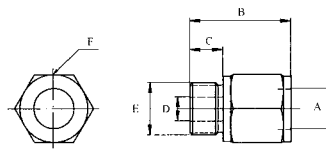

	Part No.	UNF/UN (E)	A	B	C	D	F (hexagon)	
COUPLING — O-Ring Boss	Series 826, 1/4"	14 826 0407	7/16"-20	10.0	35.4	9.0	4.5	20
	Series 826, 3/8"	14 826 0609	9/16"-18	13.0	39.9	10.0	7.0	24
	Series 826, 1/2"	14 826 0812	3/4"-16	16.0	40.5	11.0	9.5	28
		14 826 0814	7/8"-14	16.0	42.1	12.6	12.7	28
		14 826 0817	1 1/16"-12	16.0	44.5	15.0	14.5	28
	Series 826, 3/4"	14 826 1217	1 1/16"-12	23.0	55.0	15.0	15.0	32
	Series 826, 1"	14 826 1621	1 5/16"-12	30.0	64.0	15.0	21.0	41

# Coupling

## External G-Thread with Integral Rubber Seal

### Working Pressure

1/4"	5076 PSI (350 bar)
3/8"	5076 PSI (350 bar)
1/2"	5076 PSI (350 bar)
3/4"	5076 PSI (350 bar)
1"	3625 PSI (250 bar)

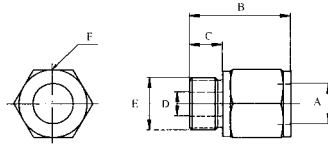

Rubber seals comply with  
DIN 3869

	Part No.	Connection (E)	A	B	C	D	F (hexagon)	
COUPLING – G-Thread	Series 830, 1/4"	14 830 0404	G 1/4"	10.0	38.0	12.0	4.5	20
	Series 830, 3/8"	14 830 0606	G 3/8"	13.0	41.0	12.0	7.0	24
	Series 830, 1/2"	14 830 0808	G 1/2"	16.0	43.0	14.0	9.5	28
	Series 830, 3/4"	14 830 1212	G 3/4"	23.0	56.0	16.0	15.0	36
	Series 830, 1"	14 830 1616	G 1"	30.0	69.0	18.0	21.0	41

# Coupling

## Metric (ISO 6149 – 3)

### Working Pressure

14 831 0612	5076 PSI (350 bar)
14 831 0616	4570 PSI (315 bar)
14 831 0818	4570 PSI (315 bar)
14 831 1222	4570 PSI (315 bar)
14 831 1227	2900 PSI (200 bar)

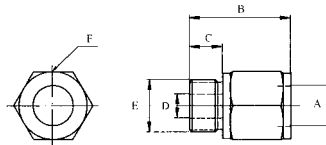

	Part No.	Connection (E)	A	B	C	D	F (hexagon)	
COUPLING – Metric	Series 831, 3/8"	14 831 0612	M12x1.5	13.0	40.9	11.0	6.0	24
		14 831 0616	M16x1.5	13.0	41.4	11.5	7.5	24
	Series 831, 1/2"	14 831 0818	M18x1.5	16.0	42.0	12.5	9.5	28
	Series 831, 3/4"	14 831 1222	M22x1.5	23.0	53.0	13.0	14.0	32
		14 831 1227	M27x2	23.0	56.0	16.0	15.0	32

# Coupling

## Bulkhead

### Working Pressure

1/4"	5076 PSI (350 bar)
3/8"	5076 PSI (350 bar)
1/2"	5076 PSI (350 bar)

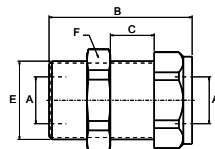

	Part No.	A	B	C	E	F (hexagon)	
COUPLING – Bulkhead	Series 813, 1/4"	14 813 0444	10.0	42.8	0-18	M21.5 x 1.5	22
	Series 813, 3/8"	14 813 0646	13.0	50.8	0-25	M26 x 1.5	27
	Series 813, 1/2"	14 813 0848	16.0	50.0	0-25	M30 x 2	32

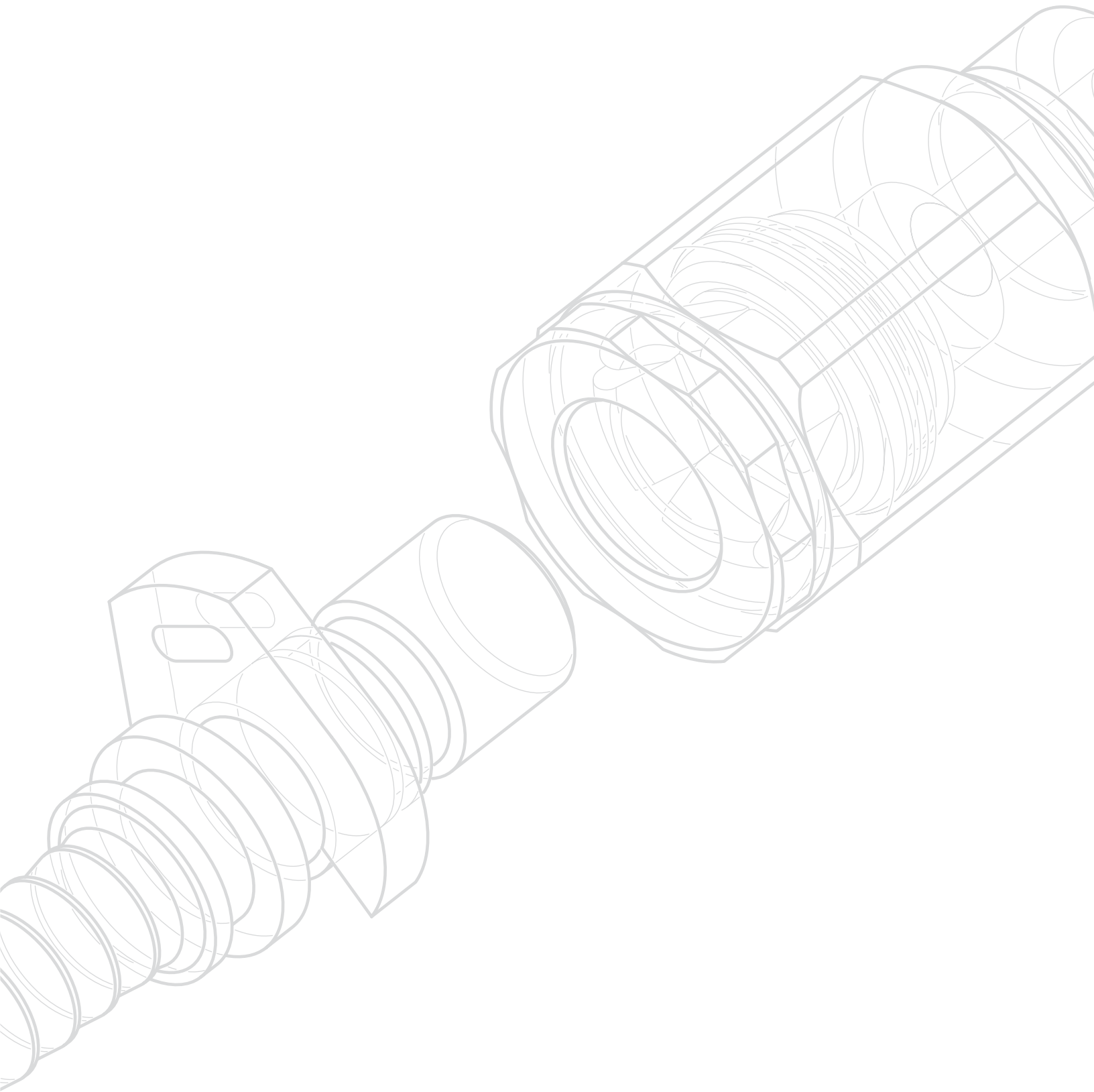

## **Other Products Available from CEJN**

*To obtain product information or product brochures, contact your nearest CEJN office or representative, or visit us on the Internet at [www.cejn.com](http://www.cejn.com)*



*The Global*  
**Quick Connect Specialist**